



**F5-45XX/85XX Copper/Optical
Ethernet to 4/8E1 Converter
User Manual
(Version 1.1)**

Beijing Fibrbridge Co., Ltd.

Content

1. Overview	3
2. Features	4
2.1. Hardware.....	4
2.2. Software	5
3. Applications.....	7
Peer-to-peer application with standalone	7
4. Specification	8
4.1. E1 Interface	8
4.2. Ethernet Optical Interface.....	8
4.3. Ethernet Electric Interface	9
4.4. Power	10
4.5. Environment	10
4.6. Dimension & Weight.....	10
5. Operation Instruction.....	11
5.1. Panel sketch map.....	11
5.2. LED Description	12
5.3. Button Description	14
5.4. DIP Switch Description	15
5.5. Port Description.....	15
6. Installation & Operation	16
6.1. Installation Steps	16
6.1.1. Preparation	16

6.1.2.	Connection.....	17
6.1.3.	Power ON and the Indicators status.....	19
6.2.	Notice	19
6.3.	Faults & Solutions	20
6.3.1.	Power LED OFF.....	20
6.3.2.	LOS LED ON	20
6.3.3.	No alarm, but can't transfer data.....	20
7.	Order Information.....	20

1. Overview

This series of products are orientated in the broadband access system for its high-quality, high-stability and low price. F5-45XX/85XX is the most newly promoted product that can map 100Base-FX and 10/100Base-T Ethernet data into 4/8 E1 channels. This protocol converter provides bandwidth up to 7.936Mbps (for 4E1, for 8E1 is 15.872Mbps) for Ethernet connection. And it also provides completed indicators to show the status and alarm messages of the E1 channels and optical ports. It is widely used in LAN connection, IP transmission and video broadcasting. The production has the features of setting E1 channels CRC error threshold and monitoring the E1 channel working status. If the CRC error rate in any E1 channel exceeds the threshold, the system will shut down this channel automatically, and reassign the data flow to valid E1 channels. E1 ports are compatible with 75Ω unbalanced and 120Ω balanced transmission lines. The Ethernet module of all the devices has several assemblages, for example: 1 optical and 1 electric port; 4 electric ports etc. Furthermore, both chassis and standalone can be managed by the software Fi-View-PC.

2. Features

2.1. Hardware

- 1~4 E1 channels carry 100Base-FX and 10/100Base-T Ethernet data
- Comply with ITU-T G.703, G.823 for E1 ports and IEEE802.3u for Ethernet ports
- Optical port supports 100 Base-FX mode. Electric ports support 10/100Base-T mode
- Ethernet ports is in flow control and back pressure mode; support huge packet, up to 1916 bytes (inclusive); carrier sense based backpressure is selected
- 64Mbits high-speed SDRAM inside used to cache
- Rearrange Ethernet packages in E1 channels to ensure data transfer efficiency and stability
- Allow the delay time between any two channels up to 16ms
- For each E1 channel, the payload capability is up to 1.984Mbps
- Auto-detect the valid E1 channels and auto-balance the data flow among the valid E1 channels
- Provide CRC error threshold setting for each E1 channel. If the CRC error rate of any E1 channel exceeds the

threshold, the system will shut down this channel, and reassign the data flow to the valid E1 channels automatically

- Even if all the receive lines of E1 channels is shut down, the local alarm and management information can still be transferred in the transmission line. While the converter works with optical equipment, this functionality affords a convenient and efficient way to locate the fault.
- 75Ω and 120Ω line impedance are optional for E1 channels.
- Full LED on front panel provides comprehensive indication of device working status
- Indicators can be selected to indicate local or remote status
- 220VAC and -48VDC power supply for standalone and chassis are optional
- Managed/ unmanaged optional
- Provide SNMP, WEB and Console management for the standalone. Viewing and configuring local and remote device easily.

2.2. Software

- Support Console, WEB and SNMP management
- Show details of system information, including device name,

location information, IP address, start-up time, software and hardware version

- View & configure the working status of each port, including link status, link speed, duplex mode, self-negotiate status
- Configure the code error limitation、LOS、 LOF、 AIS and overtime alarm information
- Configure system setting mode, CPU or hardware configure
- Choose to show local alarm or remote alarm
- Show the detailed information of power supply, including AC/DC type, output power and running status
- Support SNMP management. Set Trap Destination, Community Name, and authority
- Provide MIB file, make it easy to be integrated into the third-party SNMP management software
- Reset device to factory default, with network configuration resetting or not selectable
- Support firmware updating, with the update tool program and new version firmware file download from our website.
- Adopt the centralized management style and the tree-view catalogue, which can manage many sets of device at the same time in a single window.

3. Applications

Peer-to-peer application with standalone

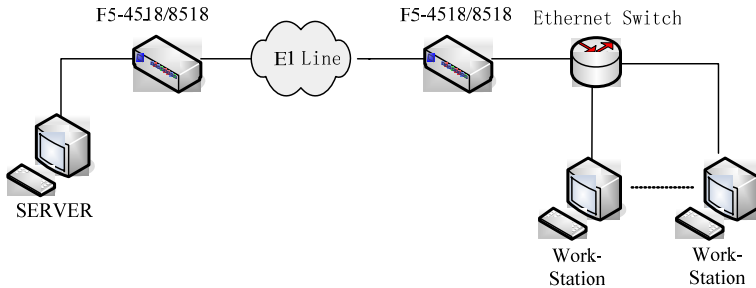
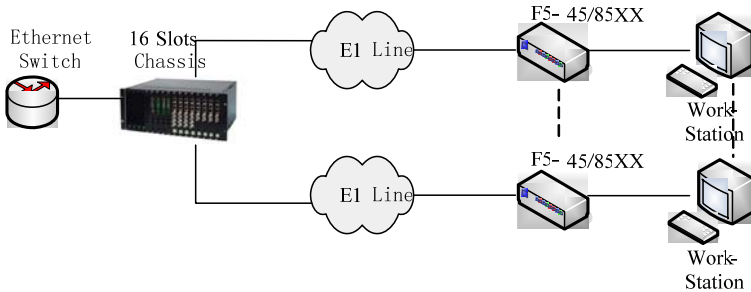

Figure1: Application topology

Star-topology with chassis and standalone



In this application, two F5-4518/8518 converters carry Ethernet data to connect hosts with LAN. LAN transmit channel is Ethernet, WAN channel is fiber.

4. Specification

4.1. E1 Interface

- Data rate: 2.048Mbps
- Code type: HDB3
- Compliant with ITU-T G.703, G.823
- Line impedance: 75Ω for unbalanced or 120Ω for balanced
- Connector: BNC for unbalanced or RJ45 for balanced
- Jitter: Compliant with ITU-T G.823
- Transparent E1 mode
- Channel number: F5-45xx: 4; F5-85xx: 8

Table1: Definition of RJ45 connector pins for 120Ω E1 ports

PIN	1	2	4	5	3, 6	Others
Description	RX+	RX-	TX-	TX+	GND	Reserved

4.2. Ethernet Optical Interface

- Adopt standard 1*9 pin optical transceiver module
- Wavelength: 850nm, 1310nm on multi-mode, 1310nm, 1550nm on single-mode
- Single mode/Multimode Optional
- Up to 120km transmission distance on single-mode, up to 5Km transmission distance on multi-mode

- SC/PC, ST/PC and FC/PC optional
- Port number: 1
- Optical Power Budget List:

Table 2: Optical Power Budget

Wave length (nm)	Connector	Emit Power (dBm)	Sensitivity (dBm)	Saturation (dBm)	Max Dist. (Km)	Loss (dBm/Km)
MM850	SC/ST	-14 ~ -18.5	-31~ -34	-14	2	3
MM1310	SC/ST	-14 ~ -18.5	-31~ -34	-14	5	2
SM1310	SC/ST/FC	-6 ~ -15	Better than -34	-3	40	0.4
SM1310	SC/ST/FC	3 ~ -3	Better than -36	-3	80	0.4
1550 DFB	SC/ST/FC	3 ~ -3	Better than -36	-3	120	0.25

4.3. Ethernet Electric Interface

- Speed: auto-negotiation
- Compatible with IEEE802.3u
- Connectors: RJ-45
- Duplex mode: auto-negotiation

- MDI/MDI-X auto crossover
- Design specially for supporting VLAN package
- Transfer distance: ≤ 100 meters
- Port number: 1 ~ 4

4.4. Power

- Power Input:
 - AC Power: 198V~242VAC, 50/60Hz
 - DC Power: -48VDC
- Power Consumption: <15W

4.5. Environment

- **Operating**
 - Temperature: 0~+50°C
 - Humidity: 0~90% (non-condensing)
- **Storage**
 - Temperature: -25~+70°C
 - Humidity: 0~95% (non-condensing)

4.6. Dimension & Weight

- **Dimension**

Standalone: 435 Width × 36 Height × 233 Depth (mm)

Module: 50.6 Width × 173.4 Height × 220 Depth (mm)

- **Weight**

Standalone: 3Kg (approx.)

Module: 0.5Kg (approx.)

5. Operation Instruction

5.1. Panel sketch map

Front panel

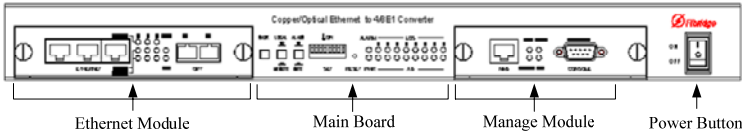

Figure 2: Front panel

Details:

Ethernet Module

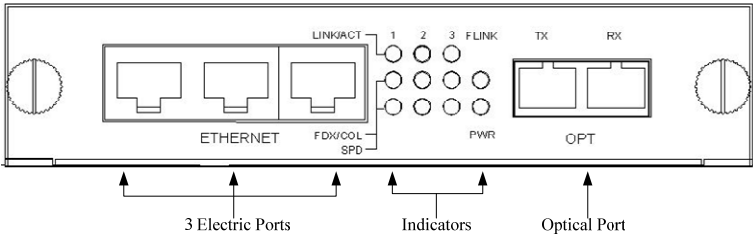

Figure 3: Ethernet Board

Main Board

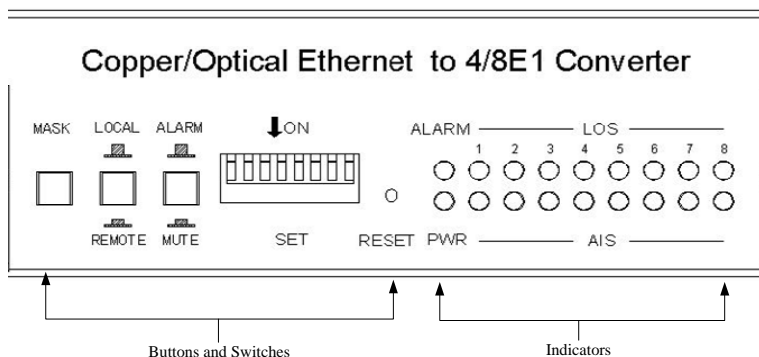

Figure 4: Main Board

Manage Module

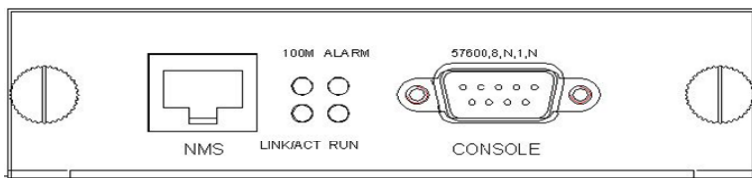

Figure 5: Manage Board

Back panel

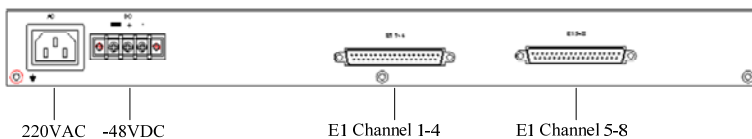

Figure 6: Back panel

5.2. LED Description

Table 3: Main Board Indicators Description

LED	Color	Status	Description
PWR	Green	ON	Power supply is OK
		OFF	Power off or failed
ALARM	Red	ON	Manage module has alarm
		OFF	Manage module has no alarm
LOS1-8	Red	ON	Local or remote E1 channel loss signal, or frame loss asynchronous
		OFF	No LOS or LOF alarm
AIS1-8	Red	ON	Local or remote E1 channel has AIS alarm
		OFF	No AIS alarm

Table 4: Ethernet Card Indicators Description

LED	Color	Status	Description
PWR	Green	ON	Power supply is OK
		OFF	Power off or failed
Flink	Green	ON	Optical port link OK
		Blink	Optical port is transferring data
		OFF	Optical port not link
Link/ ACT 1-3	Green	ON	Electric port link OK
		Blink	Electric port is transferring data
		OFF	Electric port not link
FDX/ COL 1-3	Yellow	ON	Full duplex mode
		Blink	In half duplex mode, it indicates a collision has occurred
		OFF	Half duplex mode
SPD	Yellow	ON	100M speed

1-3		OFF	10M speed
-----	--	-----	-----------

Table 5: Manage Card Indicators Description

LED	Color	Status	Description
100M	Yellow	ON	SNMP Ethernet is 100M
		OFF	SNMP Ethernet is 10M
LINK/ ACT	Green	ON	SNMP Ethernet port link OK
		BLINK	SNMP Ethernet port is transferring data
		OFF	SNMP Ethernet port not link
Alarm	Red	ON	Equipment temperature over level
		OFF	Equipment temperature normal
RUN	Green	BLINK	SNMP CPU works normally
		OFF	SNMP CPU not work

5.3. Button Description

Table 6: Button description (In the main board)

Name	Status	Description
Reset	Down	Reset equipment
	Up	Equipment works normally
MASK	Down	Mask all the alarm indicators
	Up	Not use this function
Local/ Remote	Down	Main board LED (LOS, AIS) indicate remote status
	Up	Main board LED (LOS, AIS) indicate local status
Mute	Down	Make the speaker mute
	Up	The speaker will ring when alarm occurs
Power	ON	Power ON

	OFF	Power OFF
--	-----	-----------

Default set: Power off, others up.

5.4. DIP Switch Description

Table 7: Switch description (In the main board)

Name	Bit	Stat.	Description
SET	DIP1 DIP2	OFF OFF	Local device Is controlled by hardware
		OFF ON	Local device is controlled by local management
		Else	Reserved
	DIP3	ON	Enable local E1 loop back
		OFF	Disable local E1 loop back
	DIP4 DIP5	OFF OFF	No CRC error threshold
		ON OFF	CRC error threshold is 1×10^{-4}
		OFF ON	CRC error threshold is 1×10^{-5}
		ON ON	CRC error threshold is 1×10^{-6}
	DIP6- DIP8		Reserved

Default set: All ON.

5.5. Port Description

Table 8: Port Description

Name	Description
------	-------------

Ethernet	Three electric Ethernet ports, RJ45 connector
OPT	TX: fiber transmit port
	RX: fiber receive port
NMS	SNMP management Ethernet port
Console	Console management port, baud rate is 57600, even, 8 data bits, 1 stop bit.
E1 1~4	1~4 E1 ports, connected with DB37~8BNC(75Ω) adapter or DB37~4RJ45(120Ω) cable
E1 5~8	5~8 E1 ports, connected with DB37~8BNC(75Ω) adapter or DB37~4RJ45(120Ω) cable. Not use for F5-4518

6. Installation & Operation

6.1. Installation Steps

6.1.1. Preparation

- Open the package, check the device and accessories according to the “Package List”. If any was lost or damaged, please contact us immediately.
- Make 75Ω E1 cable. There are two BNC connectors (for 75Ω E1) and one RJ45 plug (for 120Ω E1) in the package. If you want to use 75Ω interface, take out the BNC connectors, and weld them on the 75Ω E1 coaxial cable (Figure 7).



Figure7: 75Ω BNC

- Make 120Ω E1 cable. If you use 120Ω interface, take out RJ45 plug, and fix it on twister-pair cable (Figure 8). **Table 1** is the detailed definition of 120Ω connector.

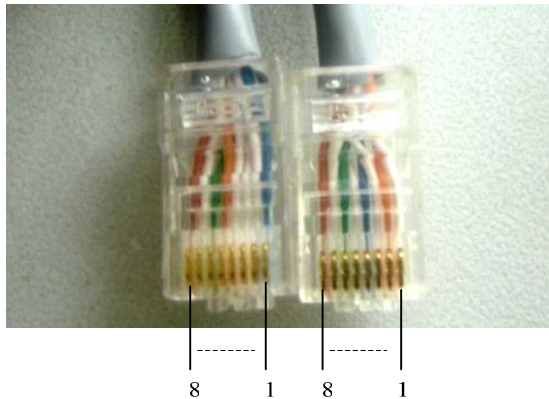

Figure 8: 120Ω RJ45

6.1.2. Connection

- Take out the equipment; place it on neat table or the other

platform.

- Connect SNMP Ethernet port (if device has management function) and Ethernet electric ports with twisted-pair cable.
- Connect E1 1~4 and E1 5~8 (for 4E1 don't connect 5~8) ports with DB37~8BNC (75Ω) or DB37~4RJ45 (120Ω) adapters, then link with 75Ω coaxial cables or 120Ω twisted-pair cables to the adapter.

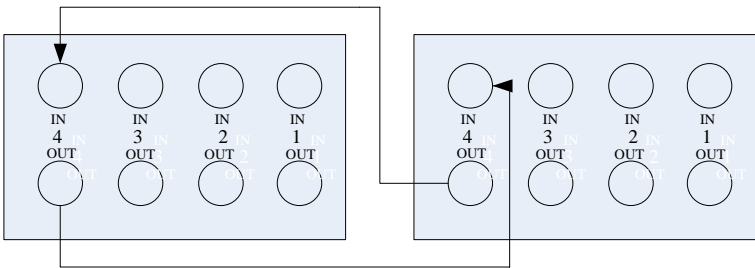

Figure 9: 75Ω connection

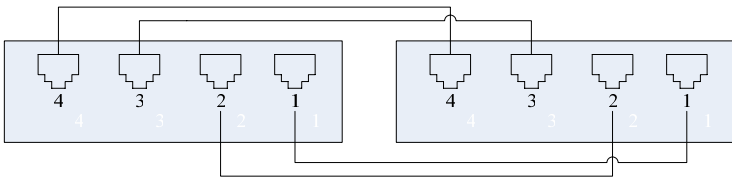

Figure10: 120Ω connection

- Connect optical ports with fiber.



Figure 11: Fiber connection

- Set buttons and dip switches. Device can work in the default mode. If you have special requirement, please set buttons or switches according to the description.
- Connect power supply cable to the equipment.

6.1.3. Power ON and the Indicators status

- If the equipment works normally, the status of indicators will be as follow:

For main board: “PWR” ON.

For Ethernet module: “PWR” ON; if Optical port is connected, “Flink” blinks; if electric ports are connected, “Link/ACT” blinks, “FDX/COL” and “SPD” ON or OFF according to the Ethernet state.

For Manage module: “RUN” blinks; if NMS Ethernet port is connected, “Link/ACT” blinks, “100M” ON or OFF according to the Ethernet state.

6.2. Notice

- E1 ports should be linked in pairs and one-to-one, e.g.,

IN1 of local end device should be connected with OUT1 of remote end device, vice versa. Otherwise, they can not receive data.

- Make sure the type of power supply is in accordance with your requirement.
- It is very important that equipments are connected to earth rightly and firmly. Check the distributing of the power supply and the connection to the earth.

6.3. Faults & Solutions

6.3.1. Power LED OFF

Please check whether the power button is “ON”.

6.3.2. LOS LED ON

Please check whether the relevant E1 channels IN and OUT are already linked, or whether it has bit errors in the channels.

6.3.3. No alarm, but can't transfer data

Please check whether E1 channels are linked in pairs and one-to-one.

7. Order Information

P/N	Description
F5-4518-1	1 optical port and 1 electric port Ethernet to 4
3-S042CA	E1 converter, standalone, 220VAC/-48VDC

/D	power supply. Optical port: single mode, 40Km, SC/PC
F5-4518-3 3-S042CA	1 optical port and 3 electric ports Ethernet to 4 E1 converter, standalone, 220VAC/-48VDC
/D	power supply. Optical port: single mode, 40Km, SC/PC
F5-4518-S 042C A/D	1 optical port Ethernet to 4 E1 converter, standalone, 220VAC/-48VDC power supply. Optical port: single mode, 40Km, SC/PC
F5-4513A/ D	1 electric port Ethernet to 4 E1 converter, standalone, 220VAC/-48VDC power supply
F5-4533A/ D	3 electric ports Ethernet to 4 E1 converter, standalone, 220VAC/-48VDC power supply
F5-4543A/ D	4 electric ports Ethernet to 4 E1 converter, standalone, 220VAC/-48VDC power supply
F5-8518-1 3-S042CA	1 optical port and 1 electric port Ethernet to 8 E1 converter, standalone, 220VAC/-48VDC
/D	power supply. Optical port: single mode, 40Km, SC/PC
F5-8518-3 3-S042CA	1 optical port and 3 electric ports Ethernet to 8 E1 converter, standalone, 220VAC/-48VDC
/D	power supply. Optical port: single mode, 40Km, SC/PC
F5-8518-S 042C A/D	1 optical port Ethernet to 8 E1 converter, standalone, 220VAC/-48VDC power supply. Optical port: single mode, 40Km, SC/PC
F5-8513A/ D	1 electric port Ethernet to 8 E1 converter,

D	standalone, 220VAC/-48VDC power supply
F5-8533A/	3 electric ports Ethernet to 8 E1 converter,
D	standalone, 220VAC/-48VDC power supply
F5-8543A/	4 electric ports Ethernet to 8 E1 converter,
D	standalone, 220VAC/-48VDC power supply
F5-4518-1	1 optical port and 1 electric port Ethernet to 4
3-S042C-	E1 converter, module card. Optical port: single
M	mode, 40Km, SC/PC
F5-8518-1	1 optical port and 1 electric port Ethernet to 8
3-S042C-	E1 converter, module card. Optical port: single
M	mode, 40Km, SC/PC
Manage	For SNMP management and can worked
Module	with all of the series listed above

Notice:

- 1. The P/Ns shown in above table are for 75ohm E1 channels only. Append suffix “-H” for each to represent 120ohm E1 channels.**
- 2. All of the devices listed above with optical port working in single mode can work in multi mode also, and the “P/N” will be changed. For example, “F5-4518-13-S042CA/D” is single mode optical, and “F5-4518-13-M042CA/D” is multi mode optical.**
- 3. All of the devices listed above support SNMP management, and the manage module is optional.**

** We Reserve the right to vary descriptions and specifications without notice due to Fibridge's policy of continuous product improvement**

Beijing FibrIDGE CO., LTD.

Address: A402, Power Creative Building, NO.1 Shangdi East
RD., Haidian District, Beijing

Tel: +86-10-58858988

Fax: +86-10-58858520

Email: info@fibrIDGE.com

Website: <http://www.fibrIDGE.com>